

# **PW1 Linear Amplifier Setup / Configuration**

Icom America Inc.

TSR

# Setting up the Icom PW1

## Using the PW1 with 1 or 2 Icom exciters

- Physical connections (1 radio)

- Physical connections (2 radios)

- “Synchronization”

- Setting the ALC levels

# Physical Connections (1 Icom radio)

There are only 3 cables required between the PW1 and an Icom radio.  
(All 3 cables are included)

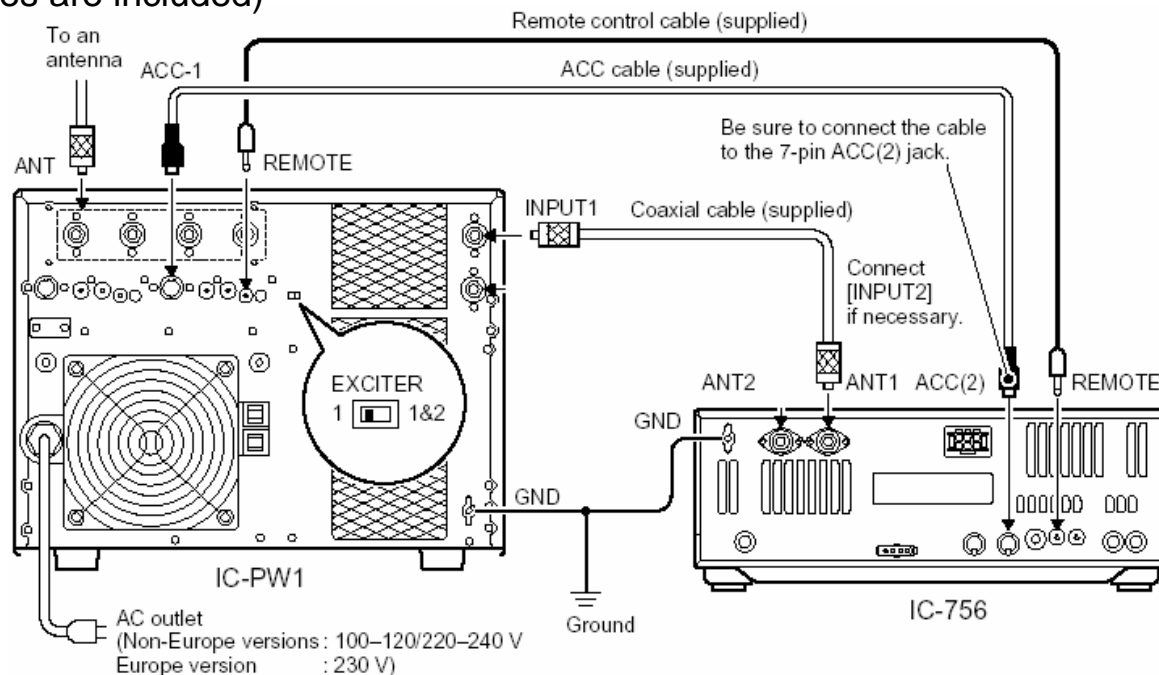

# Physical Connections (1 Icom radio)

1 “accessory” cable. (7 pin “DIN” cable)

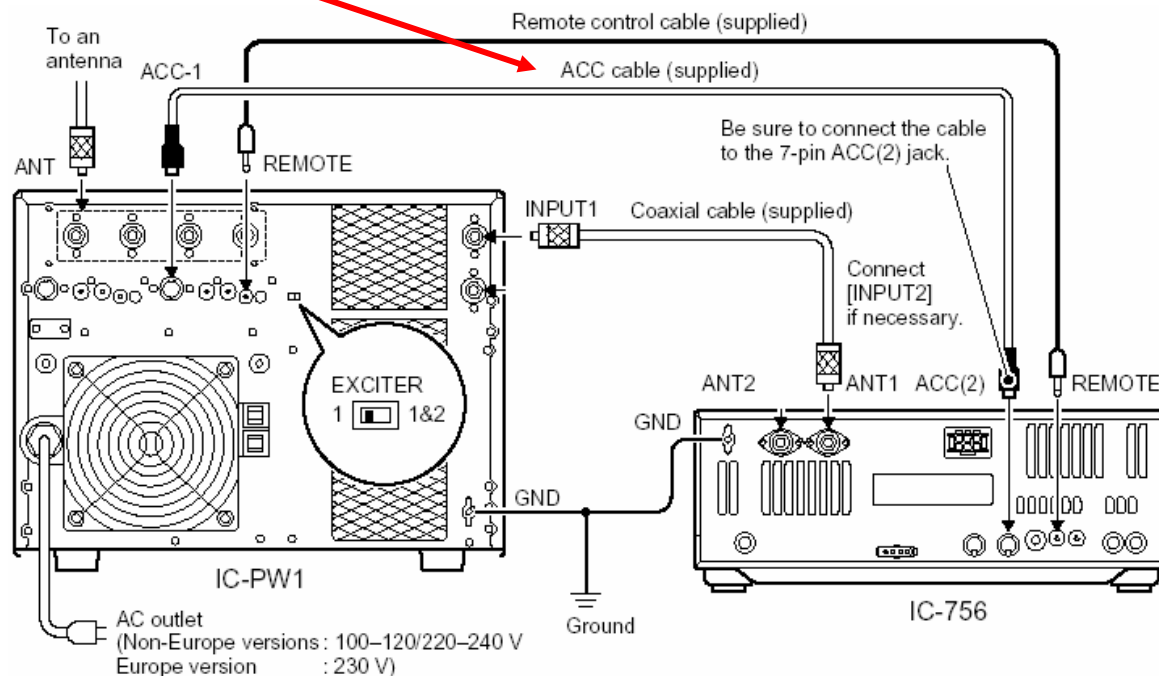

# Physical Connections (1 Icom radio)

1 "remote" cable. (3.5mm "phono" cable)

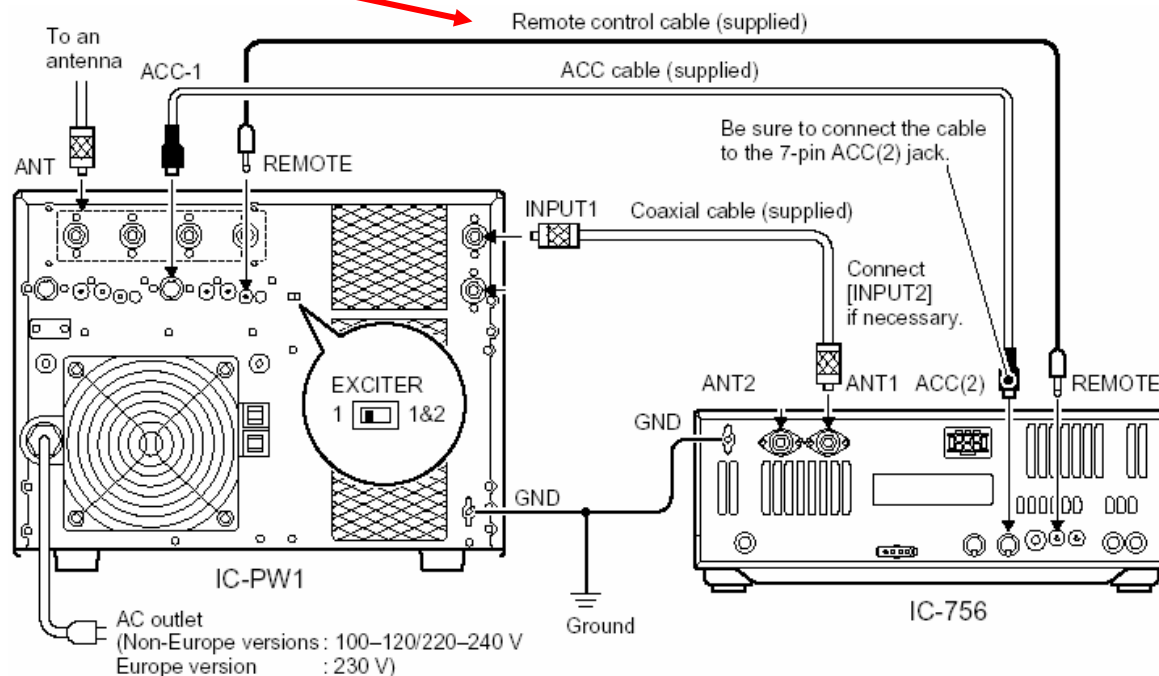

# Physical Connections (1 Icom radio)

1 coaxial cable. (50 ohm coax, RG8, etc)

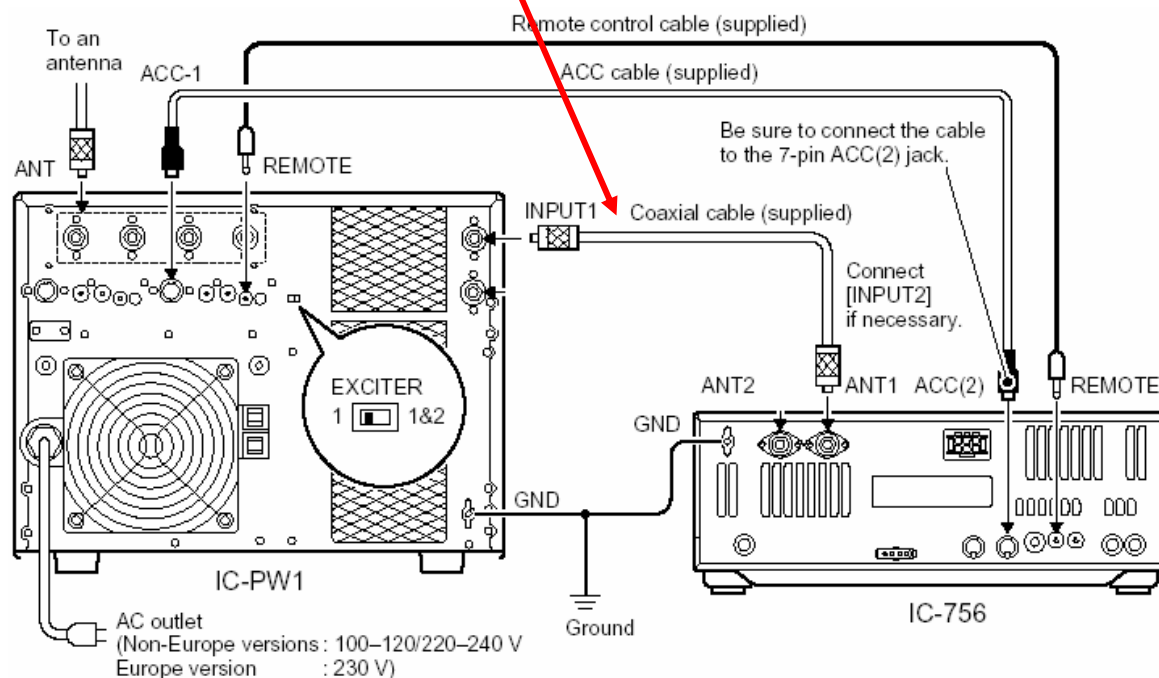

# Physical Connections (1 Icom radio)

The IC-718, 706 series or IC-7000 will also require the optional OPC 599 adapter.

- Using a 13-pin ACC socket (IC-706 series)

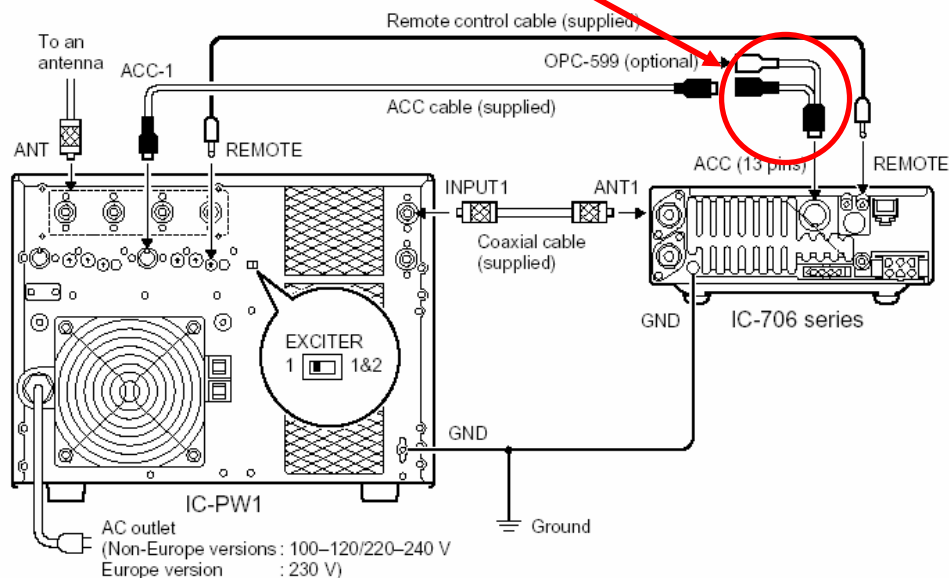

# Physical Connections (1 Icom radio)

Connect the DIN cable to the radio's "ACC 2" port (7 pin)

\*\* Note that the ports on the PW1 and radio are not labeled the same\*\*

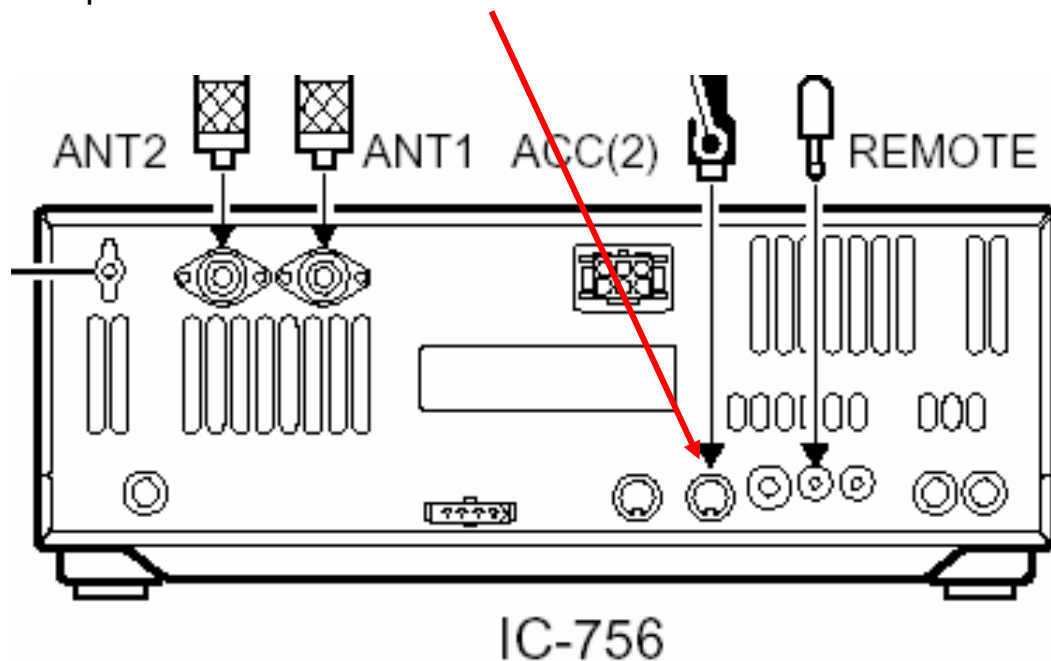

# Physical Connections (1 Icom radio)

Connect the remote cable to the radio's "remote" port

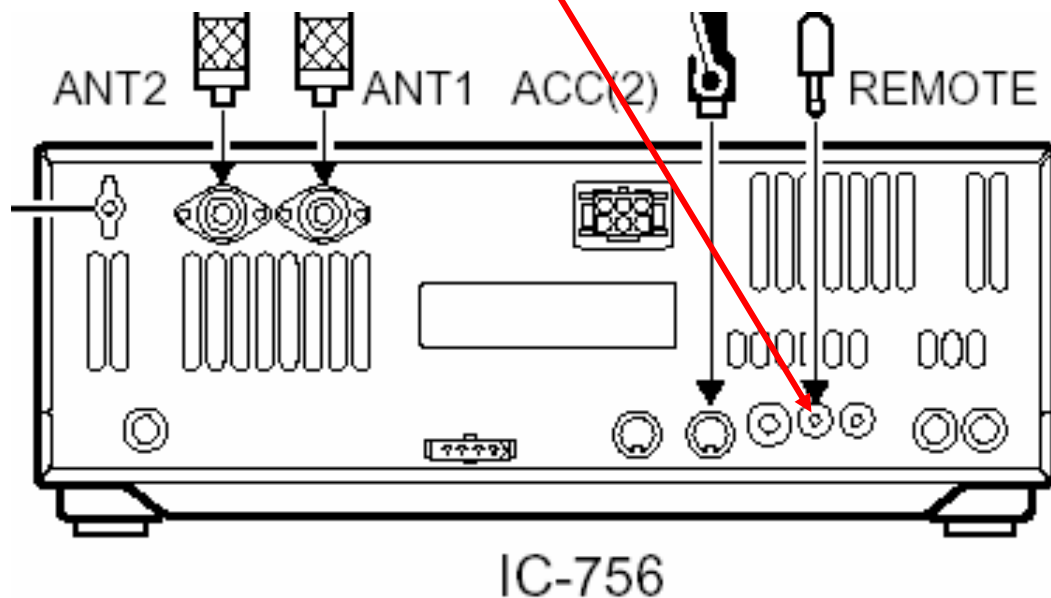

# Physical Connections (1 Icom radio)

Connect the coax cable to the radio's "ANT 1" port

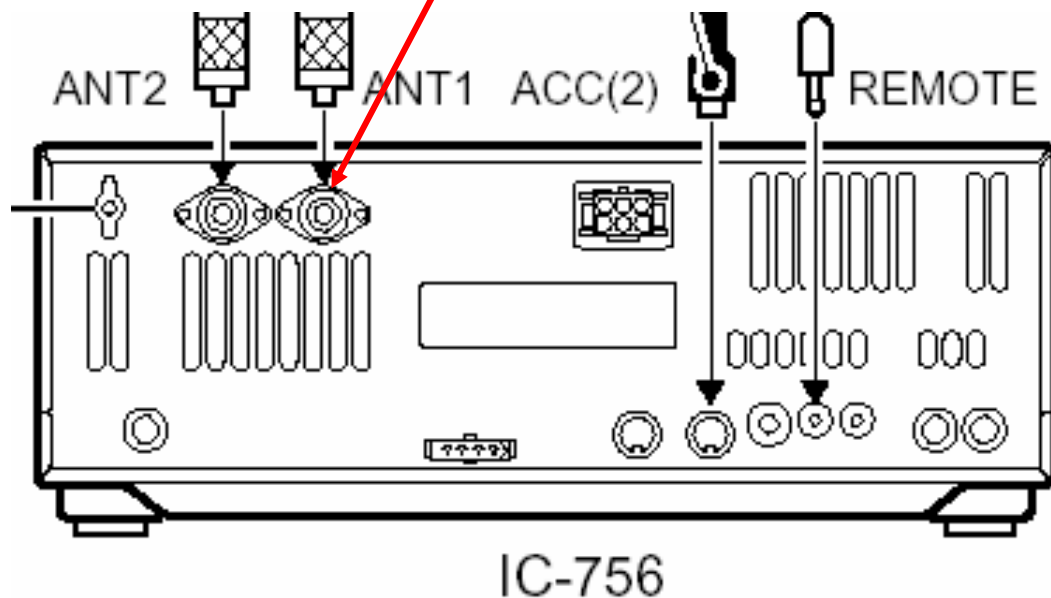

# Physical Connections (1 Icom radio)

Make sure the exciter (radio) switch is in the "1" position

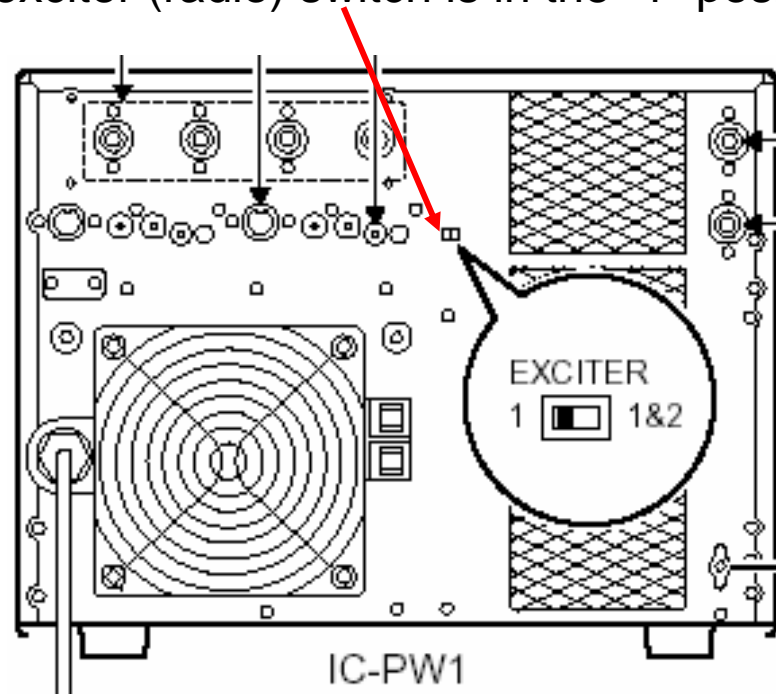

# Physical Connections (1 Icom radio)

Connect the 7 pin DIN cable to “ACC 1” of the PW1

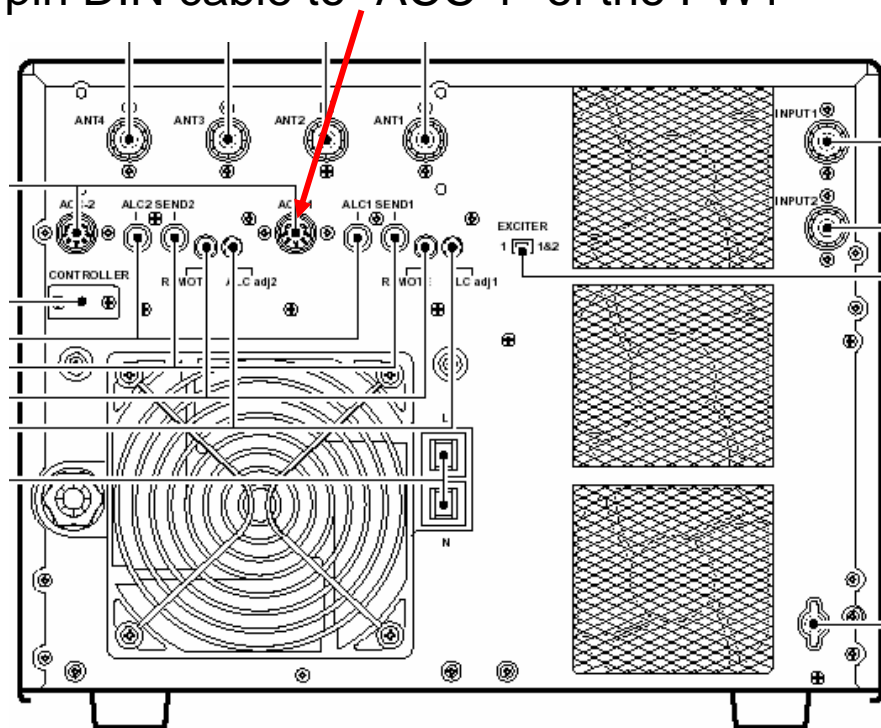

# Physical Connections (1 Icom radio)

Connect the remote cable to “remote 1” of the PW1

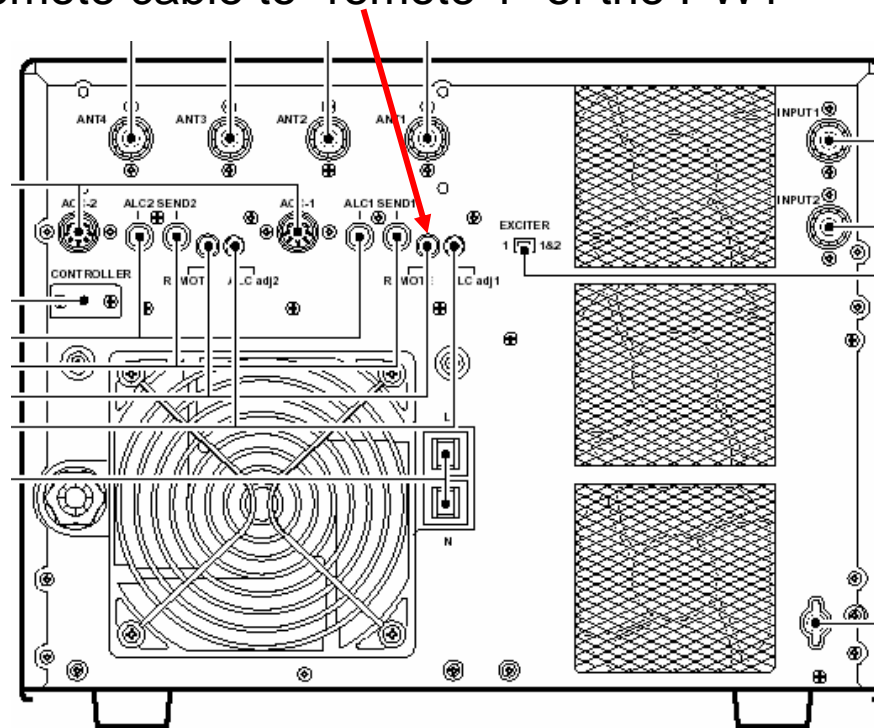

# Physical Connections (1 Icom radio)

Connect the coax cable to “Input 1” of the PW1

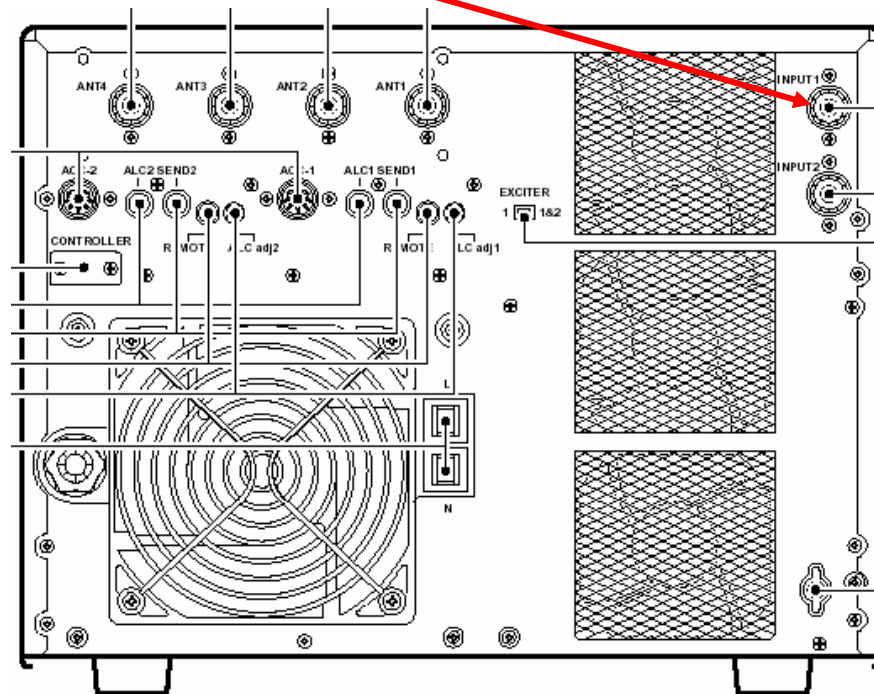

# Physical Connections (1 Icom radio)

Connect your antenna to “ANT 1” of the PW1

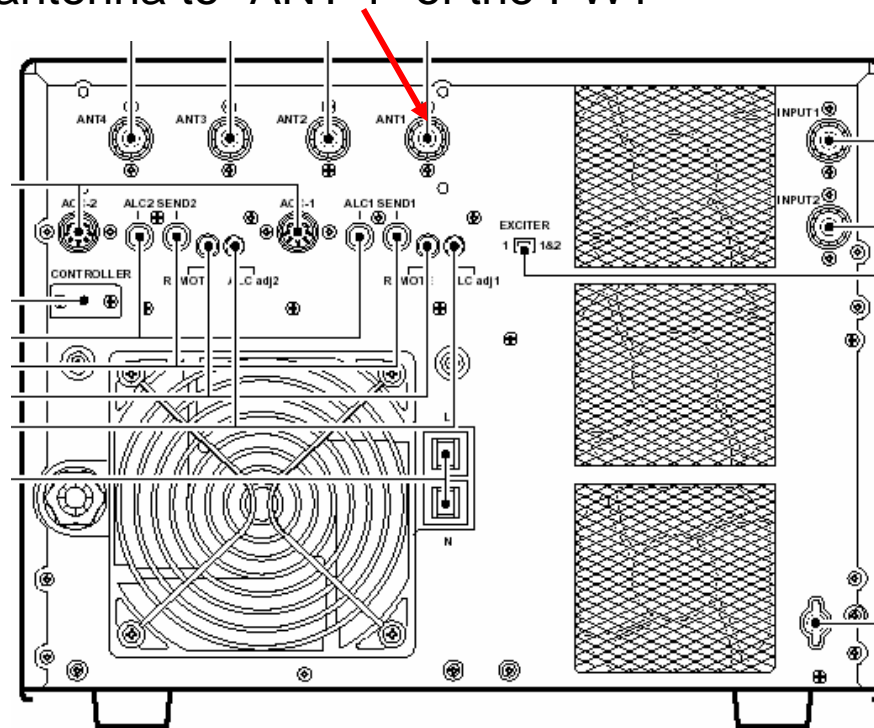

# Physical Connections (1 Icom radio)

Connect your dummy load to “ANT 4” of the PW1 (if applicable)

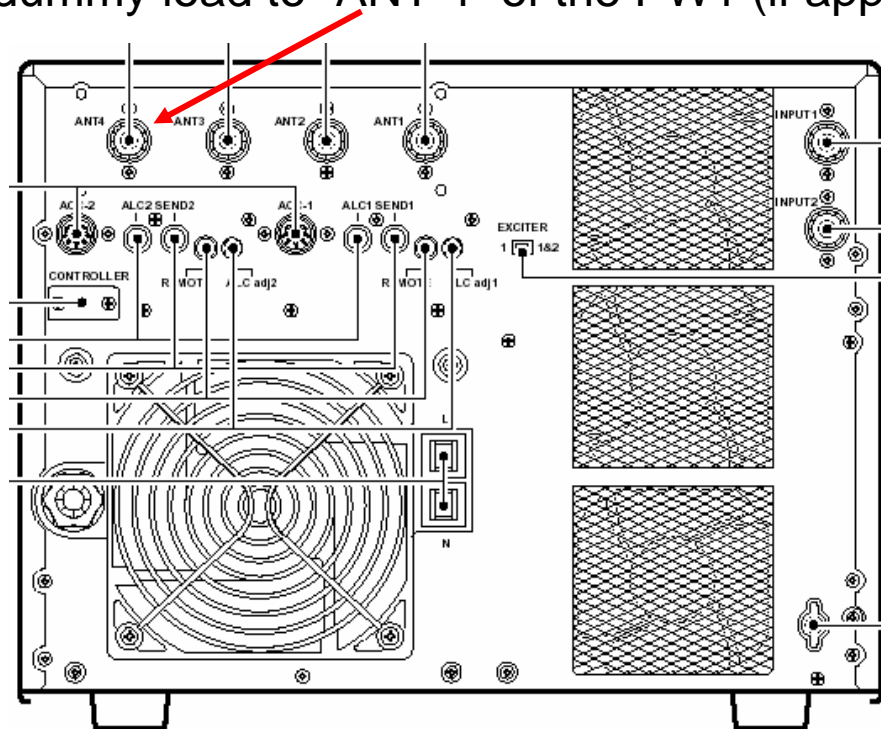

# Physical Connections (2 Icom radios)

Make sure the exciter (radio) switch is in the "1 & 2" position

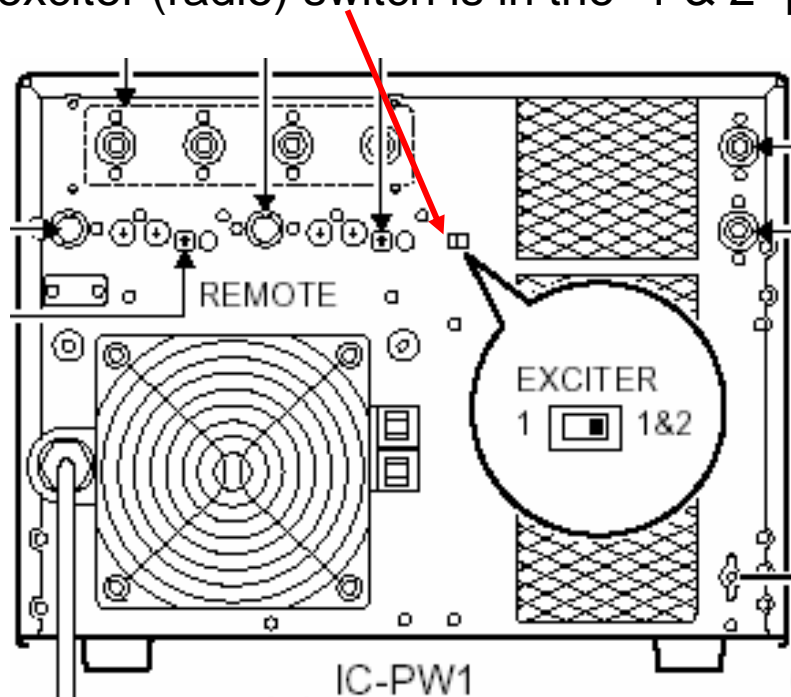

# Physical Connections (2 Icom radios)

Connect the second radio the same way, using the "2" ports of the PW1

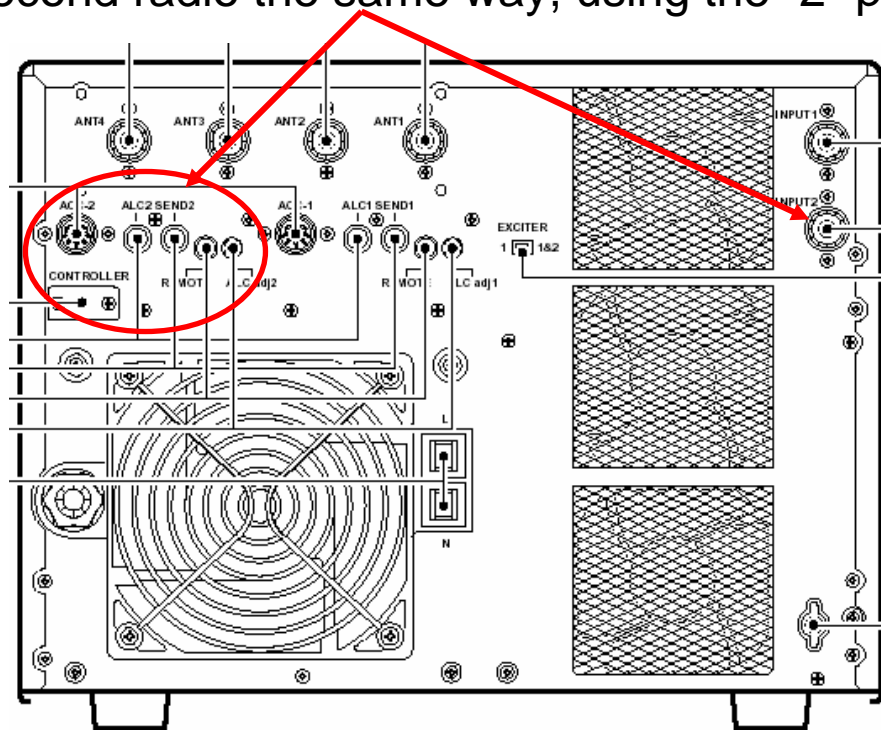

# Synchronization

The PW1 will automatically change bands, as needed, when the radio frequency is changed.

Synchronization may not be possible with a non-Icom radio.

The synchronization commands are CI-V commands sent from the radio via the remote cable.

Use of a CT-17 is not recommended with the PW1.

# Synchronization

First, make sure your radio is off, then perform a reset of the PW1 by pressing and holding the [UP] and [DOWN] buttons while turning the PW1 on.

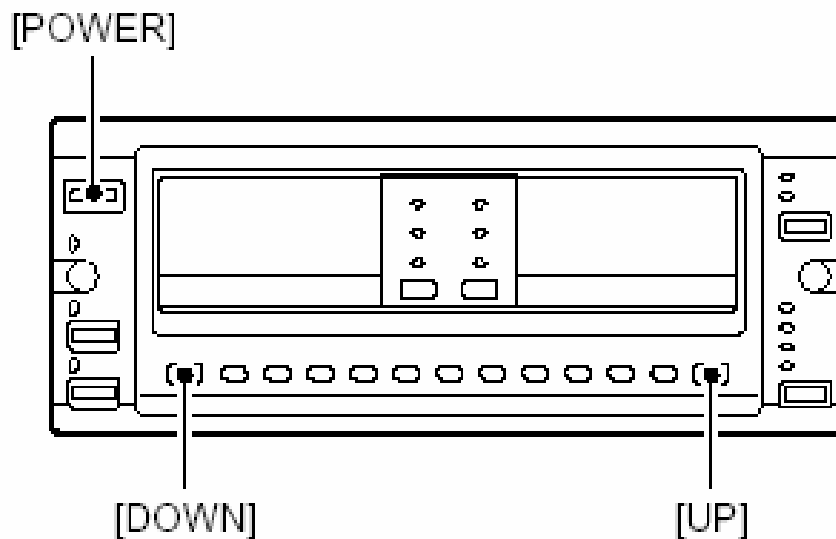

# Synchronization

Now, turn the PW1 off, hold the [input] button, and turn the PW1 back on. The green “input 1” should now be flashing.

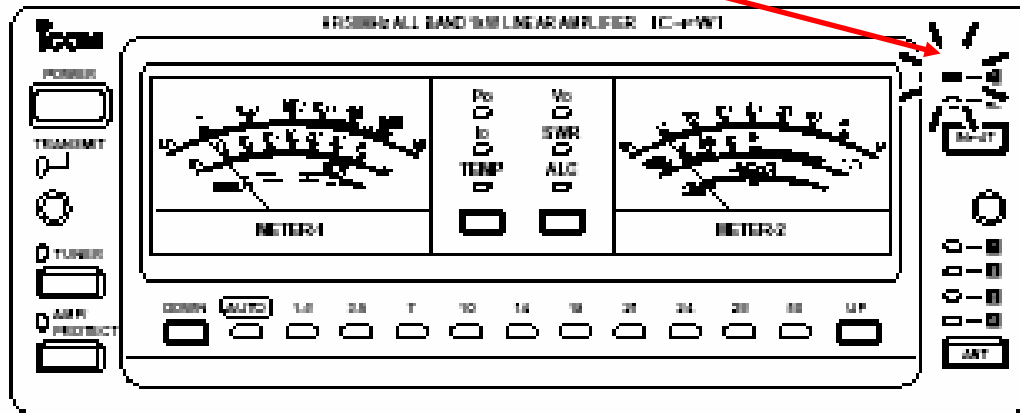

# Synchronization

Turn on your Icom radio and rotate the tuning dial on the radio until the green "input 1" lights steady.

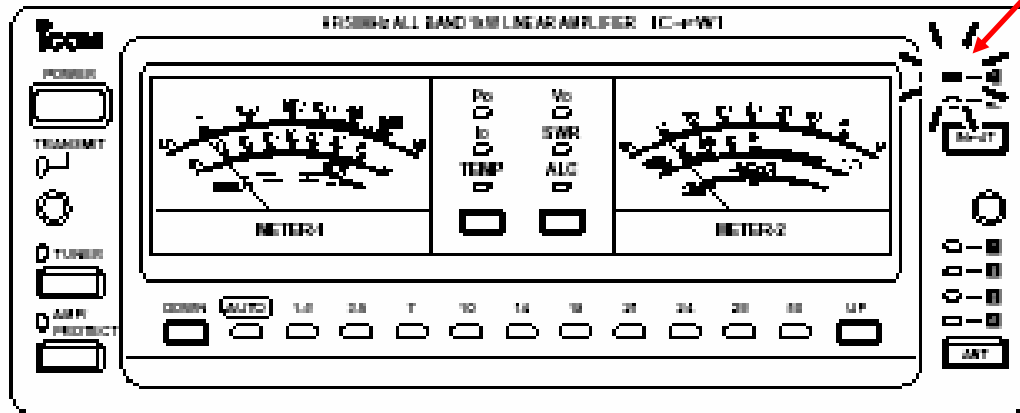

# Synchronization

If using a 2<sup>nd</sup> Icom radio, power off radio #1 and then press the [input] button to select “input 2”. Power on the 2<sup>nd</sup> radio and adjust the radio tuning knob until the light stops blinking.

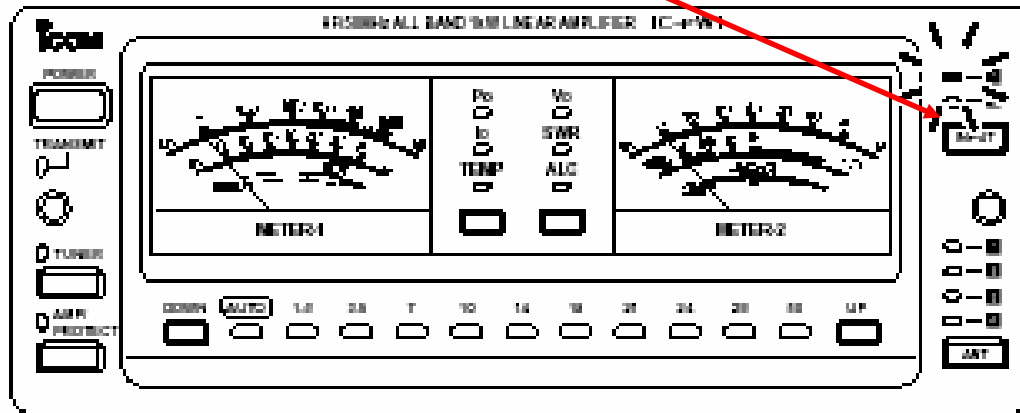

# Synchronization

Once the radio(s) are synchronized, turn off the radio(s) and the PW1. Turn the PW1 and radio(s) back on and test by changing bands on the radio. The PW1 should automatically change bands with the radio.

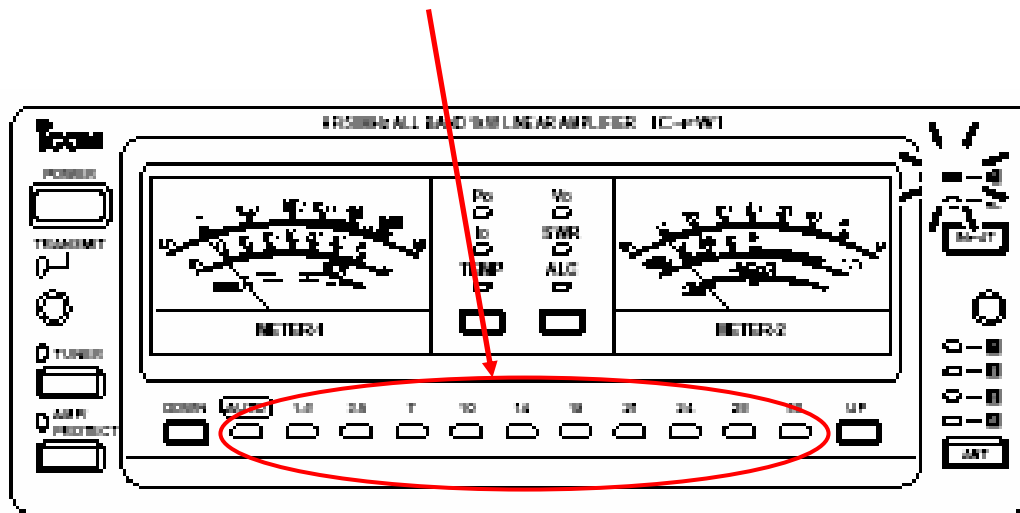

# Setting ALC Levels

The final step is to set the ALC levels for the PW1.

The procedure is the same for 1 or 2 Icom radios.

For proper calibration of the PW1, you should use a dummy load. Make sure the load being used is capable of handling the PW1's output power.

# Setting ALC Levels

First, carefully set the ALC adjustment pot on the rear of the PW1 to the minimum, fully counter-clockwise.

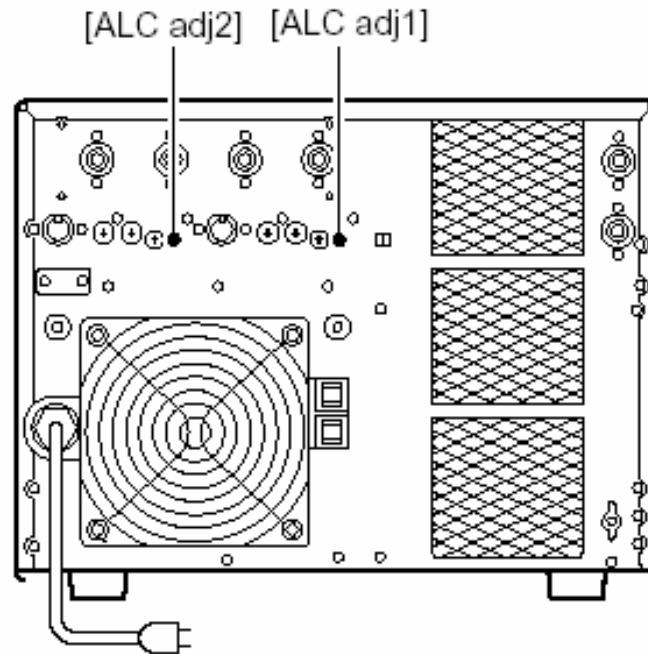

# Setting ALC Levels

Turn on the PW1 (if not already on). Press the [amp/protect] button to turn off the PW1's amp circuit. The green light should be off.

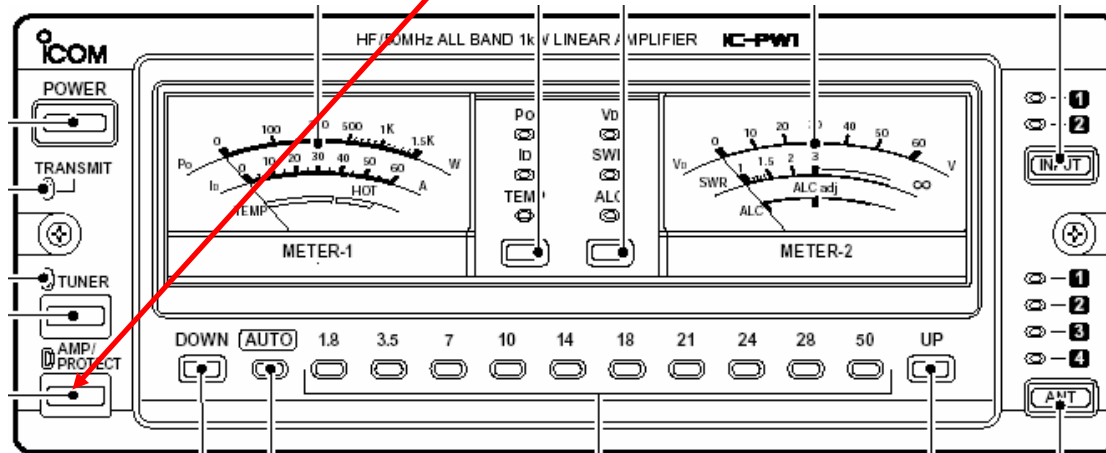

# Setting ALC Levels

Make sure the proper antenna and input are selected.

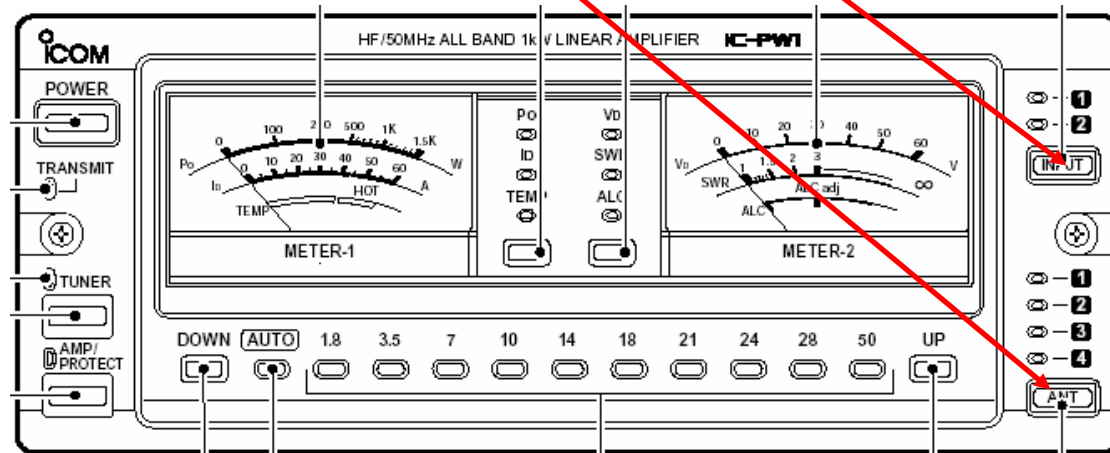

# Setting ALC Levels

Press the [tuner] button to turn on the PW1's tuner circuit. The green light should be on.

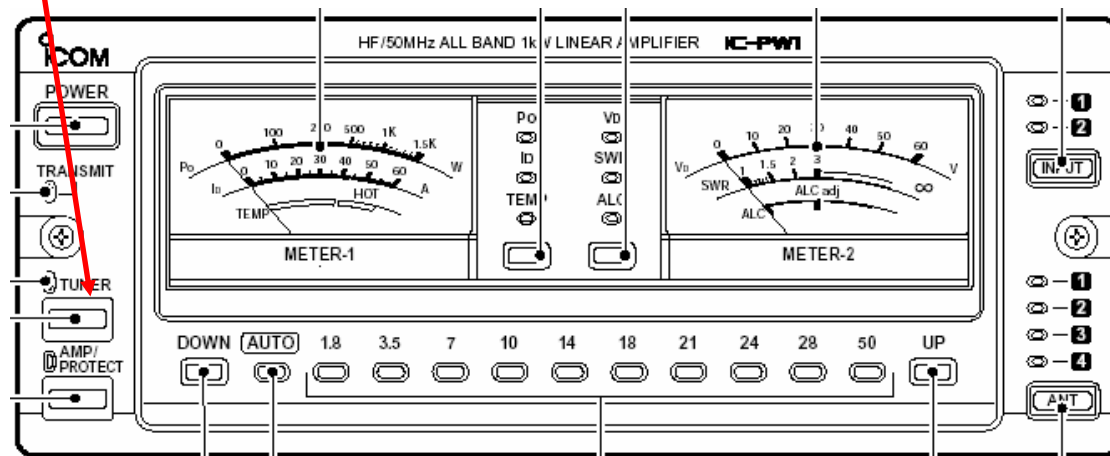

# Setting ALC Levels

Set the left meter to display “power” and the right to display “ALC”.

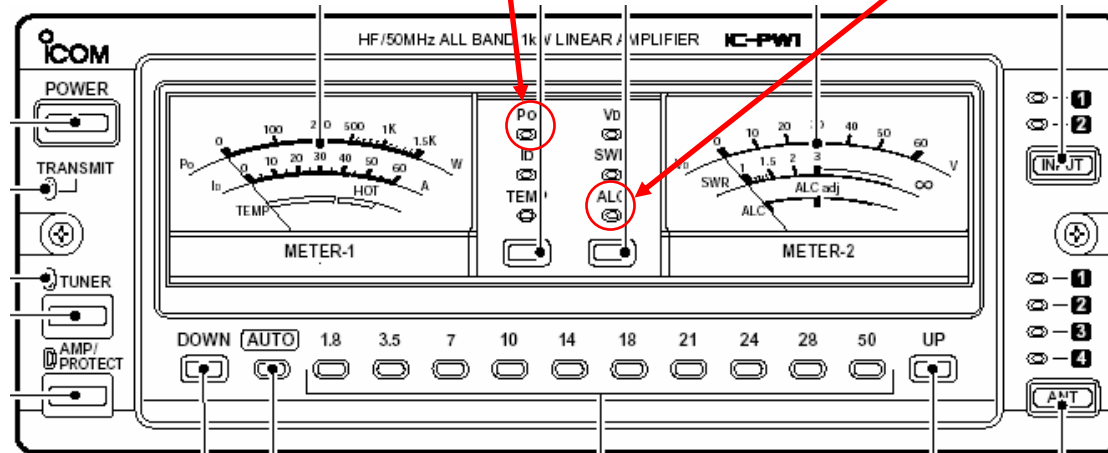

# Setting ALC Levels

Set the radio to RTTY mode and transmit at 100 watts. You should see about 100 watts on the power meter of the PW1.

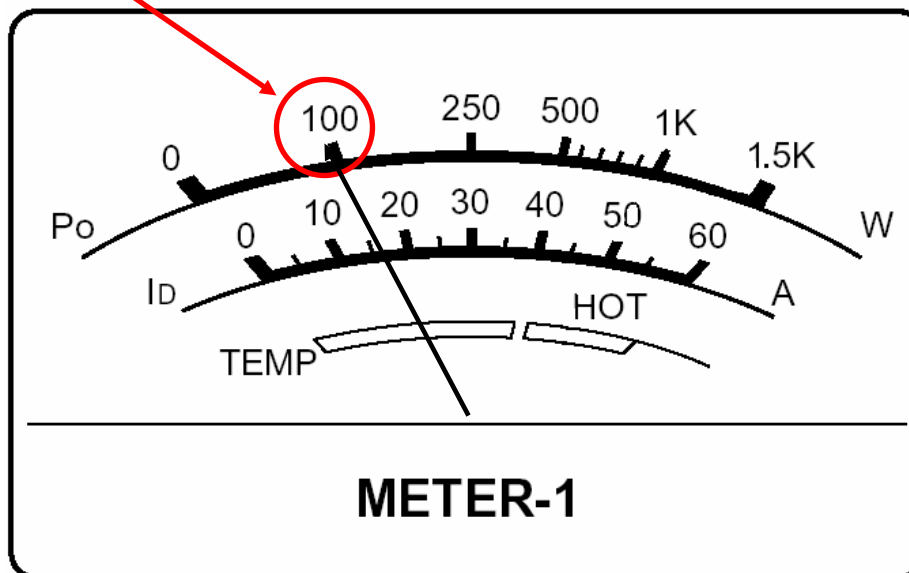

# Setting ALC Levels

Stop transmitting and press the [amp/protect] button to turn the PW1's amp back on. The green light should be on.

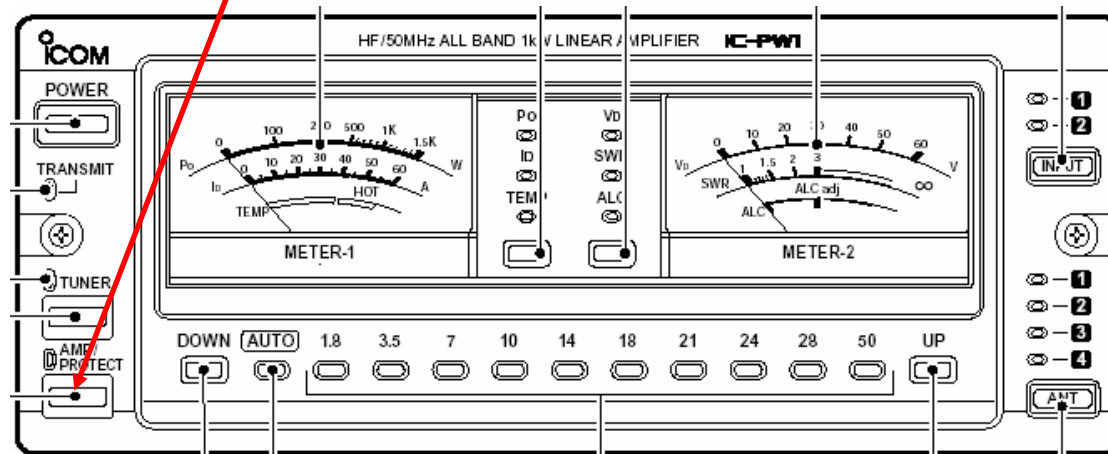

# Setting ALC Levels

Be ready to adjust the ALC adjust screw on the PW1. Transmit from the radio and carefully adjust the ALC until the meter shows mid-scale, as shown below. Once set, stop transmitting.

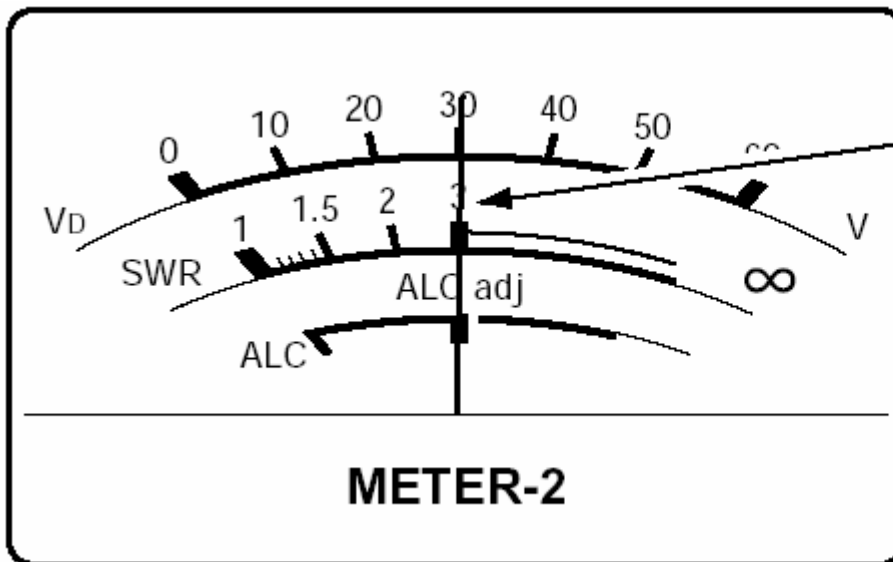

ALC adjustment  
point

# Setting ALC Levels

Once the ALC level is set, you should see the power output of 1KW with 240VAC or 500W with 120VAC.

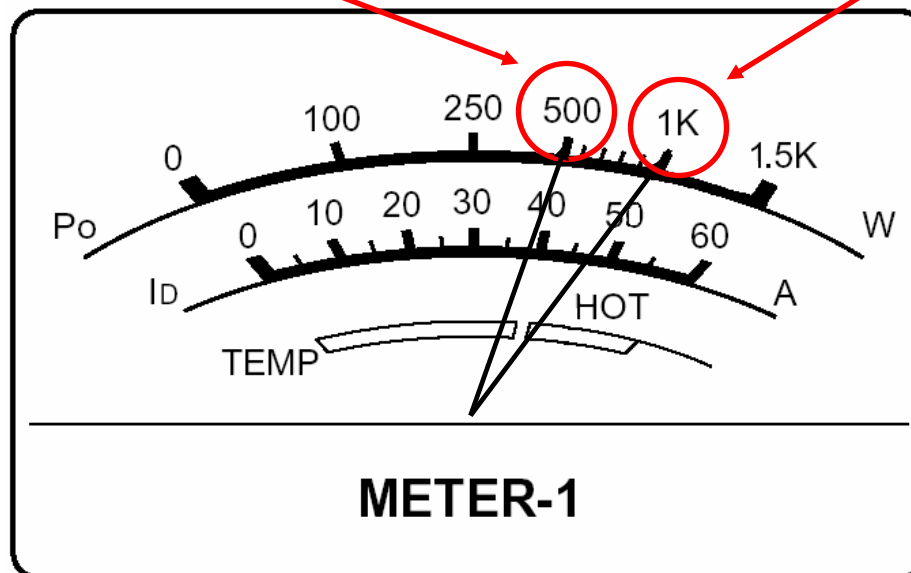

# Your PW1 is now ready for use!

When watching the radio's power meter, you will notice that the ALC circuit limits and controls the radio's power output. You will see about 40-60 watts actual power output from the radio when operating the amp.

Non-Icom radios may or may not use the ALC feature. It is recommended to not use ALC with a non-Icom radio and to control the power manually on the radio.

A "relay buffer" for keying the PW1 is highly recommended when using a non-Icom radio.